

# Tire Pressure & Temperature Monitoring System (TPTMS)

Nitish Patel<sup>1</sup>, Anish Giri<sup>1</sup>, Sudhakar Kumar Sah<sup>1</sup>, Hasibullah Habibi<sup>1</sup>,  
Mrityika Dewanjee<sup>2</sup>, Ashish Kumar Singh<sup>3</sup>

<sup>1</sup>Dept. of CSE, Faculty of Engineering and Technology, Jain University, Bengaluru,  
Karnataka, India.

<sup>2</sup>Dept. of ISE, Faculty of Engineering and Technology, Jain University, Bengaluru,  
Karnataka, India

<sup>3</sup>Dept. of CSE, Faculty of Engineering and Technology, Jain University, Bengaluru,  
Karnataka, India.

[nitishpatel.npl@gmail.com](mailto:nitishpatel.npl@gmail.com), [anishgiri71@gmail.com](mailto:anishgiri71@gmail.com), [ss8880288@gmail.com](mailto:ss8880288@gmail.com),  
[hasibullah.habibi2015@gmail.com](mailto:hasibullah.habibi2015@gmail.com), [mrityikamitu26@gmail.com](mailto:mrityikamitu26@gmail.com),  
[s.ashish@jainuniversity.ac.in](mailto:s.ashish@jainuniversity.ac.in)

## Abstract

*Tire Pressure and Temperature Monitoring System (TPTMS) presently simply keeps an eye on the pressure of the tyres. However, once its tyre pressure level and temperature are known, no unique responses take place. Driving comfort and safety is determined by tyre pressure and temperature. In order to merge a TPTMS, a Pressure Sensor Base (PSB), and a Temperature Sensor Base (TSB) with a specific reaction necessary to fulfil tyres automatically, this research provided a solution. Using Splunk Enterprise, the Tire Pressure Temperature Monitoring system is presented to monitor changes in tyre pressure and temperature. The Rpi is used in conjunction with a 5-inch HDMI Touch Display, SPD100g Pressure Sensor, and DS18B20 Temperature Sensor to create the suggested system. The system detects high and low tyre pressures, as well as tyre temperature, and presents the data on the display. Splunk Enterprise indexes the log from the Tire Pressure and Temperature Sensor Monitoring System. Splunk Enterprise is a search, analytics, and visualisation platform for machine-generated data from apps, sensors, and devices. It interacts with various log files and stores file data in the form of events in local indexes. Dashboards and Reports can be built with Splunk Enterprise Pivots. Throughout the ability to successfully track these so qualities, which may be in vehicles of course, but also during or after the mass manufacturing of tyres by industries, so that the desired amount of standard set of values is achieved, it is our goal to have a design for the TPTMS that is viable for all kinds of vehicles with tyres and one which can be used as a unit in so many industry sectors and areas.*

**Keywords:** Splunk Enterprise, SPD100g Pressure Sensor, DS18B20 Temperature Sensor, Raspberry Pi 3, 5-inch HDMI Touch Display.

## 1. Introduction

Tire pressure is meant to monitor the air pressure inside the pneumatic tyres on cars and plays a vital part in vehicle safety and fuel consumption considerations. Vehicles that travel with low or high tyre pressure use more gasoline. If air leakage from the tyre is not discovered, it might cause major problems while the car is running. As a result, real-time tyre pressure monitoring in automobiles is a significant aspect. The indirect approach and the direct method are the two types of TPTMS monitoring schemes available. The indirect technique, such as TPTMS with the Circumference method and TPTMS with the Frequency method, is based on the wheel speed signal. The Direct approach relies on a pressure & temperature sensor, such as a TPTMS pressure & temperature sensor. The downside of the indirect approach is that the data is not exact, there is a high rate of failure, and it is difficult to maintain, whereas the direct method is highly accurate and quick to discover. As a result, the Direct approach is used in the suggested system.

The driver receives real-time tyre pressure information via the gauge, pictogram display, and warning or indicator light. To show tyre pressure & temperature, the suggested system employs gauges and indicator lights. Because a tire's safety parameters are intimately tied to its pressure & temperature, TPTMS systems have the capability of measuring tyre pressure & temperature. Almost all TPTMS systems use electronic devices in small modules installed adjacent to the valve and on the outer section of the rim, in other words, inside the tyre, to measure the physical values of pressure with particular sensors.

The suggested project is built on an embedded system that uses a Raspberry Pi 3 as a low-cost ARM-powered Linux computer. The Raspberry Pi 3's ARM Cortex 64-bit embedded platform enables floating-point calculations, which improves the system's real-time speed.

## 2. Literature Survey

**I.** A contemporary car contains numerous sensors that are dispersed throughout the vehicle. These sensors communicate with the car's electronic control units (ECUs) and deliver messages that the vehicle either acts on or displays to the driver. The temperature of the car's key components, as well as the climate control for the vehicle cabin, is monitored by sensors. Other sensors help with steering, acceleration, and braking, all of which are important for the vehicle's driver-assisted functioning. As vehicles become more autonomous and closer to achieving Level 5 self-driving capabilities, the overall number of sensors used in vehicles grows year after year.[1]

**II.** With the use of a wireless network and wireless charging/remote charging, a system is devised to monitor the tyre pressure of any type of car. The pressure sensor detects low or excessive pressure within the tyre and alerts the kit, which subsequently generates a sound alarm. The signal is transmitted by wireless communication, which can be Bluetooth or Wi-Fi, and wireless charging is utilised to charge the tyre pressure kit battery.[2]

**III.** uses unique integration techniques to provide a TPMS solution that delivers real-time tyre pressure monitoring in both stationary and moving conditions, as well as alerting the driver to underinflated tyres. A pressure sensor, microprocessor, RF transmitter, and long-life battery are all included in the unit. The TPMS unit uses an onboard RF receiver to communicate and displays real-time tyre pressure for all four tyres.[3]

IV. The use of wireless communication to monitor tyre pressure was proposed. An electronic unit is directly screwed onto the tyre stem in the proposed TPMS. A pressure sensor and switch, a signal conditioning unit, a microprocessor, an RF transmitter, and a battery are all included in the unit. The TPMS device connects with an OnboardRF receiver, which displays real-time tyre pressure for all tyres. To prevent erroneous data from being received from neighbouring vehicles, the system and each TPMS device have a unique ID code. When tyre pressure reaches the maximum or lowest safe pressure levels, or when it varies abruptly, the alert is triggered. The user interface allows them to modify the lower and higher limits of tyre pressure or the safe range of rapid changes.[4]

### 3. Hardware Description

The suggested Embedded system uses a Raspberry Pi 3 board with an ARM Cortex Microprocessor to monitor tyre pressure in real-time with Splunk Enterprise. Tire pressure and temperature are monitored in autos using a 5-inch HDMI display, SPD100G pressure sensor, and DS18B20 temperature sensor.

#### **Block Diagram:**

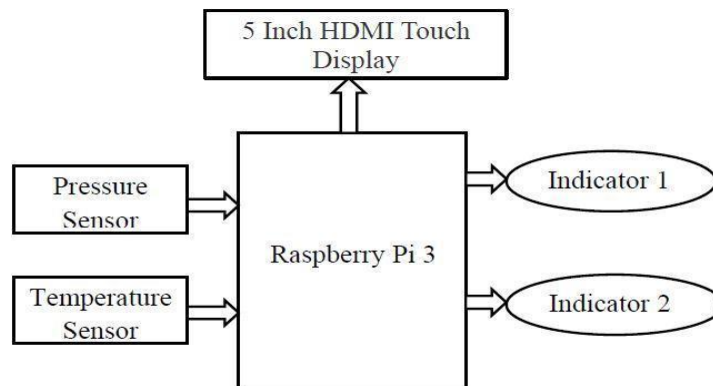

Fig no. 1  
(Block diagram for the proposed system)

Figure 1, depicts the block diagram of the proposed system for real-time tyre pressure & temperature monitoring. The data is displayed on a 5-inch HDMI monitor that is connected to the Raspberry Pi and shows the various pressures and temperatures of the tyre. The log management process in Splunk Enterprise is powered by a machine learning algorithm.



Fig no. 2  
(HDMI Display interfaced with Raspberry pi)

Figure 2, shows how Dashboards and Reports are built using the Machine learning process in Splunk Enterprise Pivots.

The HDMI display interface with Raspberry Pi is shown in Figure 2. It includes a standard HDMI interface and can be directly plugged into a Raspberry Pi with a resolution of 800 480 pixels and a capacitive touchpad that also offers touch control.

Pressure sensors from the Smart Pressure Device SPD series are available in two different types: gauge and absolute. It is based on bridge resistance, which provides a very precise digital interface. It is a pressure gauge that measures pressure in kilopascals (kPa) (kPa). It has a pressure range of 0-650 kPa that it can measure.

#### 4. Software Description

The suggested system makes use of Splunk Enterprise, which employs machine learning methods such as regression and classification to collect, deploy, evaluate, transform, and visualise tyre pressure monitoring system data logs.

##### 4.1 Splunk Enterprise 7.2.0

Splunk Enterprise is a data collection, management, and analysis tool. Sensors, devices, and operational technology can provide real-time information. The key features include the ability to search for and examine a certain result, create dashboards to visualise and analyse data logs, and save data for later use as shown in the figure no 3. The advantages include real-time processing, the ability to enter data in any format, including CSV (Comma Separated Values), JSON (Javascript Object Notation), and others, and the ability to precisely forecast the resources required for scaling up the infrastructure.

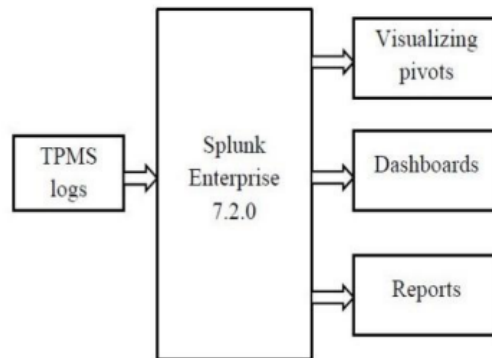

Fig no. 3  
(Block diagram of Splunk Enterprise)

#### 4.2 Splunk Components

The components of Splunk Enterprise are shown below, Splunk Forwarder, Splunk Indexer, and Search Head are the three essential components. The forwarder is used to forward data, whereas the indexer is used to parse and index the data. Searching, analysing, and reporting are all done with the search head.

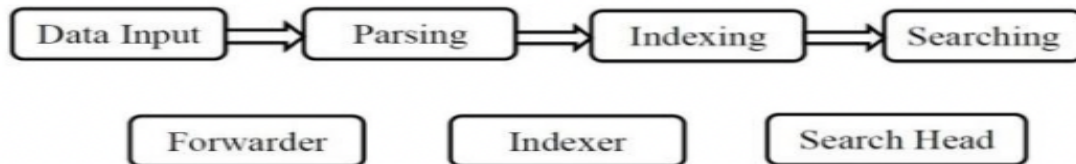

Fig.4: Splunk Components

#### 4.3 Visualization

The visualisation aids in the clear and precise communication of complicated ideas and data patterns. Splunk offers a variety of ways to create reports and dashboards that illustrate the search results generated by the data it has indd. The ability to retrieve large amounts of data is one of the most essential advantages of visualisation. Splunk offers a variety of chart formats to help you visualise your data.

#### 4.4 Dashboards

Dashboards are a collection of searches, visualisations, and input elements that capture and present information. Dashboards are a common way to measure and track performance, and they're also a good way to keep track of specific data. Splunk offers several options for producing useful dashboards based on searches and visual visualisations. Using Splunk for monitoring frequently results in a dashboard with many visualisations. The report panels on a dashboard can be a chart, gauge, table, or list of search results.

#### 4.5 Machine Learning Algorithm

Splunk Enterprise uses the decision tree algorithm, a machine learning technique, to search and predict indexed data. It's a method for predicting outcomes using predictor

variables. Both classification and regression trees use decision trees. To fit a model to predict the value of a categorical variable, a decision tree estimator is used.

## 5. Experimental Results

In the proposed effort, around 10log datasets of tyre pressure monitoring pressure were processed. Splunk Enterprise is used to process the TPTMT logs and provide visualisations such as pivots, dashboards, and reports.

### 5.1 Experimental Setup



Fig.5 Experimental Setup

Figure 5 depicts the tyre pressure monitoring system's experimental setup. Raspberry Pi, 5-inch HDMI display, and SPD100G pressure sensor make up the test setup.

### 5.2 Hardware Results



Fig 6. The Temperature Gauge

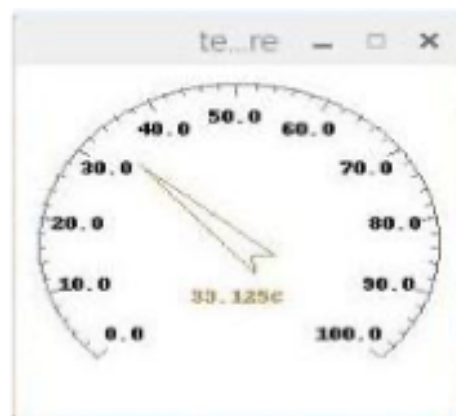

Fig 7. The Pressure Gauge

The tyre pressure & temperature information displayed in the gauge is shown in the figure 6 and figure 7 above, Kilopascal is the unit of measurement for pressure. Temperature sensor measures the temperature from 9- bit to 12-bit celsius.

### 5.3 TPTMS Logs

The temperature and tire pressure records are tallied. A complete record of each resource used in process assistance and troubleshooting can be found in the log data. The various pressure and temperature logs are displayed in Table 1.

Table 1:TPTMS

| Logs   | Pressure (kPa) | Temperature (°C) |
|--------|----------------|------------------|
| Log 1  | 175            | 33.125           |
| Log 2  | 99             | 29.896           |
| Log 3  | 193.053        | 36.321           |
| Log 4  | 186.158        | 34.964           |
| Log 5  | 151.685        | 30.874           |
| Log 6  | 158.579        | 31.220           |
| Log 7  | 199.948        | 38.534           |
| Log 8  | 206.843        | 40.475           |
| Log 9  | 248.211        | 44.631           |
| Log 10 | 227.527        | 42.176           |

### 5.4 Splunk Dashboard Results

The display made with Splunk Enterprise is displayed in Figure 8. This dashboard, also known as the Tire Pressure Monitoring Dashboard, shows the low temperature, high temperature, low pressure, and high-pressure dashboards.

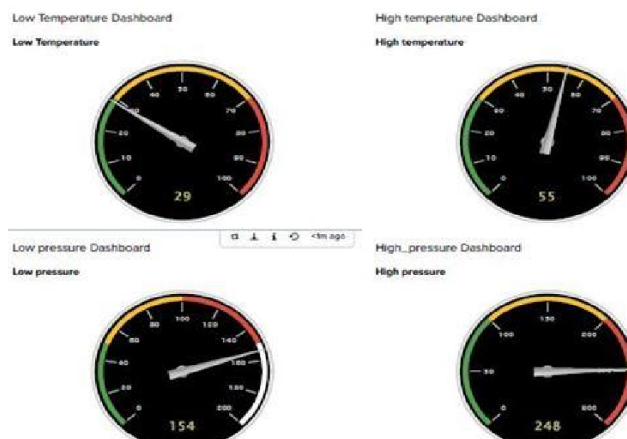

Fig.8: Splunk Dashboard

## 6. Conclusion

The pressure of car tyres is monitored in this study utilising a real-time tyre pressure monitoring system based on Splunk Enterprise. The TPTMS logs are indexed and monitored in real-time using the Splunk Enterprise tool with the machine learning toolkit, which includes visualisation pivots, dashboards, and reports. As a result, it can be used to assess system performance, troubleshoot any failures, and track business data. This system is also compatible with a laptop, smartphone, or another mobile device.

## 7. Acknowledgements

We would like to express my gratitude to my mentor Ashish Kumar Singh for providing support and guidance. I got to learn a lot more about this project which will be very helpful for me.

In the end, we would like to thank my parents. Without them, I would not have been able to write this research paper.

## 8. References

1. S. Abdelhamid, H. S. Hassanein, and G. Takahara, "Vehicle as a Mobile Sensor," *Procedia Computer Science*, vol. 34, pp. 286–295, Jan. 2014. [Online]. Available: <http://www.sciencedirect.com/science/article/PII/S1877050914008801>
2. Snehal R.Javheri, Biplap Kumar and Bej Raj Singh Patel, "Wireless Tire Pressure Monitoring System for Motor Vehicles", International Conference on Ubiquitous and Future Networks (ICUFN), pp. 744-748, June 2017
3. Sharmila and Vibin Mammen Vinod, "Design of a Real-Time Tire Pressure Monitoring System for LMV's", International Conference on Green Engineering and Technologies (IC- GET), pp. 103-106, 2016
4. Nouman Naim Hasan, Adeel Arif, Muhammad Hassam, Syed Shabeeh and Usman Pervez, "Implementation of Tire Pressure Monitoring System with Wireless Communication", International Conference on Communication Computing and Control Applications, 2011.

### Authors



**Name:** Nitish Patel

**Affiliation:** Faculty of Engineering & Technology, Jain University, Bengaluru, India.

**Profile:** Nitish Patel is a second-year undergraduate student in the Department of Computer Science and Engineering, Faculty of Engineering and Technology, Jain University, Bengaluru, Karnataka, India. He comes from an Internet of things background. He has worked on projects based on IoT. His research interest is also in the field of IoT Devices & Applications.



**Name:** Anish Giri

**Affiliation:** Faculty of Engineering & Technology, Jain University, Bengaluru, India.

**Profile:** Anish Giri is a second-year undergraduate student in the Department of Computer Science and Engineering, Faculty of Engineering and Technology, Jain University, Bengaluru, Karnataka, India. He comes from an Internet of things



background. He has worked on projects based on IoT. His research interest is also in the field of IoT Devices & Applications.



**Name: Sudhakar Kumar Sah**

**Affiliation: Faculty of Engineering & Technology, Jain University, Bengaluru, India.**

**Profile:** Sudhakar Kumar Sah is a second-year undergraduate student in the Department of Computer Science and Engineering, Faculty of Engineering and Technology, Jain University, Bengaluru, Karnataka, India. He comes from an Internet of things background. He has worked on projects based on IoT. His research interest is also in the field of IoT Devices & Applications.



**Name: Hasibullah Habibi**

**Affiliation: Faculty of Engineering & Technology, Jain University, Bengaluru, India.**

**Profile:** Hasibullah habibi is a second-year undergraduate student in the Department of Computer Science and Engineering, Faculty of Engineering and Technology, Jain University, Bengaluru, Karnataka, India. He comes from an Internet of things background. He has worked on projects based on IoT. His research interest is also in the field of IoT Devices & Applications.



**Name: Mrityika Dewanjee**

**Affiliation: Faculty of Engineering & Technology, Jain University, Bengaluru, India.**

**Profile:** Mrityika Dewanjee is a second-year undergraduate student in the Department of Information Science and Engineering, Faculty of Engineering and Technology, Jain University, Bengaluru, Karnataka, India. She has worked on projects based on IoT. Her research interest is also in the field of IoT Devices & Applications.



**Name: Ashish K Singh**

**Affiliation: Faculty of Engineering & Technology, Jain University, Bengaluru, India.**

**Profile:** Ashish Kumar Singh is an assistant prof. in the department of Computer Science and Engineering, FET, Jain University, Bengaluru, Karnataka, India. He comes from Electrical engineering background. He has worked on several projects linked to IoT & Power Electronics. His research interest is also in the field of Robotics & Automation & Electric Vehicles.